



F A Q

— Frequently Asked Question regarding Roller Chains —

- | | |
|--|---|
| (1) Strength of Connecting Link | (16) Example of Chain's Indication |
| (2) Method of Installing Connecting Link | (17) The Features of SBR Chain |
| (3) Wear Elongation | (18) Pin's of Fatigue Breakage Caused by Corrosion |
| (4) Temperature Limit for Chain's use | (19) Roller Chain Number |
| (5) Lubrication | (20) The kind of Attachment |
| (6) Comparison on Transmission Parts | (21) Features and Drive direction of Offset type Bushed Chain |
| (7) Allowable Load of Roller and Attachment | (22) Safeguarding of Hazards |
| (8) BCL Connecting Links | (23) Safeguarding of Hazards |
| (9) Feature of each Series | (24) Wear life and measuring method of a chain |
| (10) Stainless Steel Chain | (25) Chain Maximum Speed (V m/min) |
| (11) Matching and Tagging | |
| (12) Elastic Elongation | |
| (13) Chain Length and Sprocket Center Distance | |
| (14) Trouble Shooting Hints | |
| (15) Sprockets for Double Pitch Chain | |

(1)

Strength of Connecting Link

1. Breaking strength

Minimum breaking load of the catalog is satisfied.

2. Dynamic test load

When maximum allowable load of the catalog is adjusted to 100%...

•Main body of chain	→	100%
•New type's connecting link	→	100%
•Old type's connecting link	→	80%
•2 pitch offset link	→	75%
•1 pitch offset link	→	65%

3. Shape of connecting link

•New type's connecting link

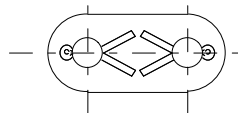

•Old type's connecting link

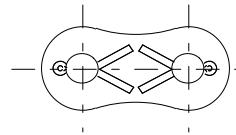

•2 pitch offset link

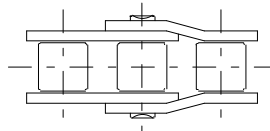

•1 pitch offset link

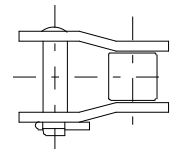

4. Notes

The elastic limit of Roller Chain is 50% of its tensile strength and that of Stainless Steel Chain is 30% of its tensile strength.

If you subject chains to tension greater than their elastic limit, they may no longer function properly and may cause damage or injury.

Never subject chains to tension greater than their elastic limit.

Method of Installing Connecting Link

1) Please install both ends of the chain onto sprockets.

Please insert pins of conn. Link into the holes of inner links from the back side of Sprocket, and please insert pins of conn. Link into the holes of conn. Link's plate from the front side of Sprocket.

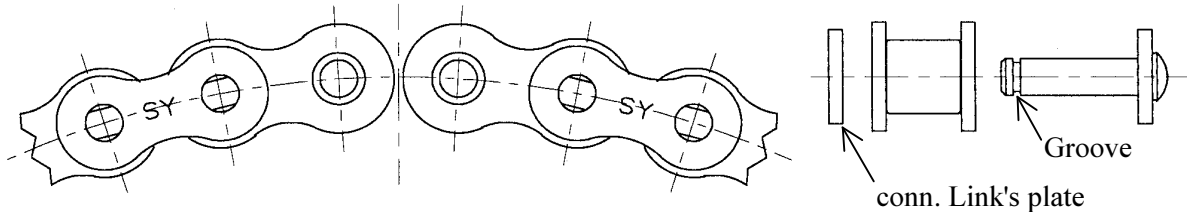

2) Please insert pins of conn. Link into holes of inner links.

3) Please insert pins of conn. Link into holes of conn. Link's plate, and please make sure to fix conn. Link's plate with cotter pin or spring clip.

In case of Press-fit conn. Link, please insert pins of conn. Link into holes of conn. Link's plate with hammer. And please make sure to fix with cotter pin or "S" pin or Spring pin.

Pins of conn. Link easily go through holes of conn. Link's plate because standard.

conn. Link is loose-fit type.



Accident may happen when spring clip or cotter pin is correctly not installed.
Please install sprig clip or cotter pin in accordance with the following drawing.
The following angle is minimum.

Spring Clip
#35~#80

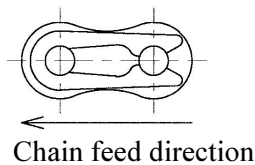

Cotter Pin
#80~#180

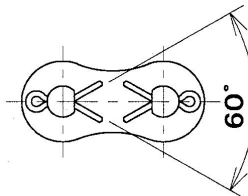

"S" pin
#200, #240

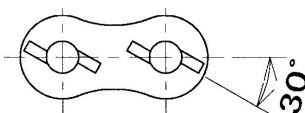

Through "S" pin
#200, #240

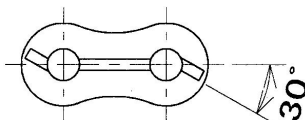

Spring clip may be bent or scratched if you hollow spring clip with screwdriver.
As indicated on the above picture, please install sprig clip, pushing its end with a pair of pliers.

Wear Elongation

Fig.1 : Factor chart

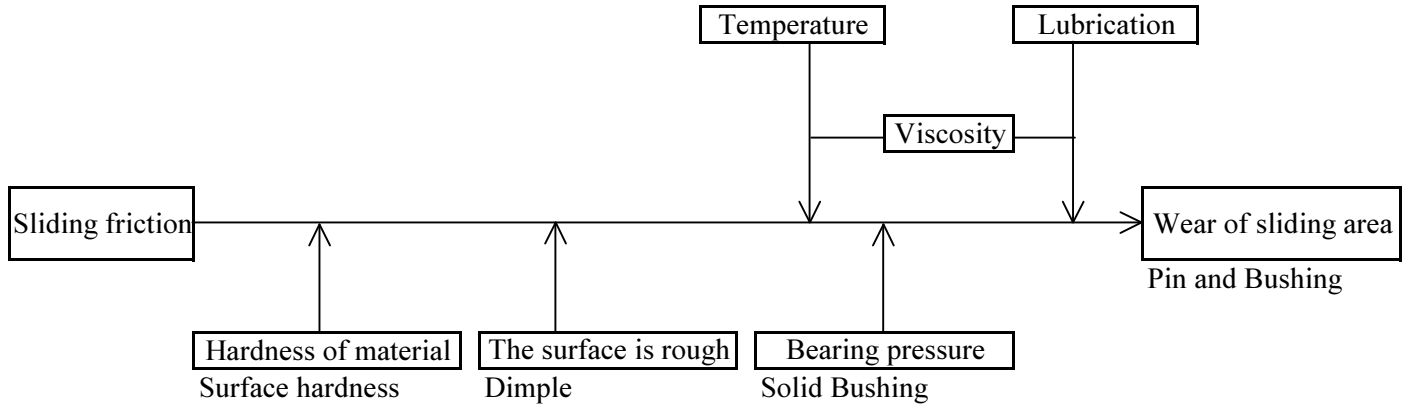
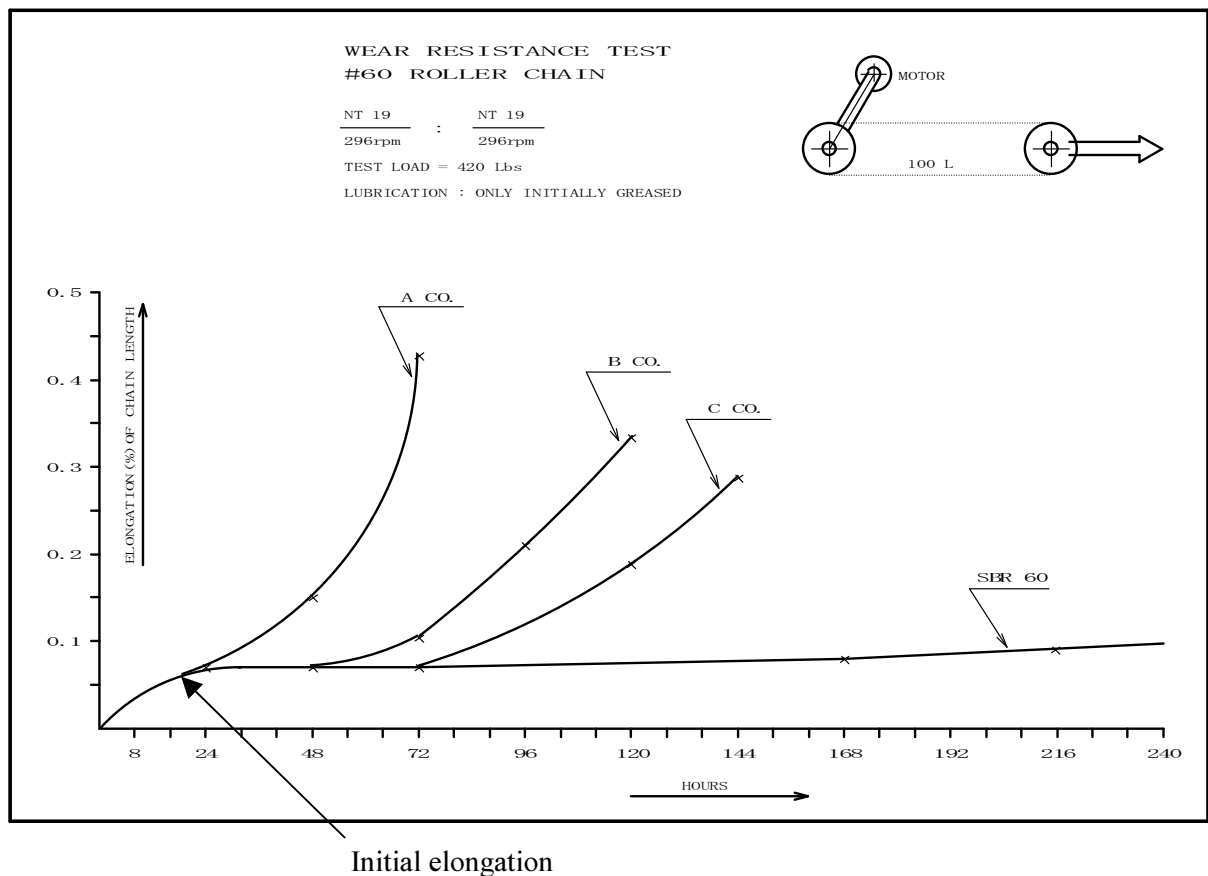
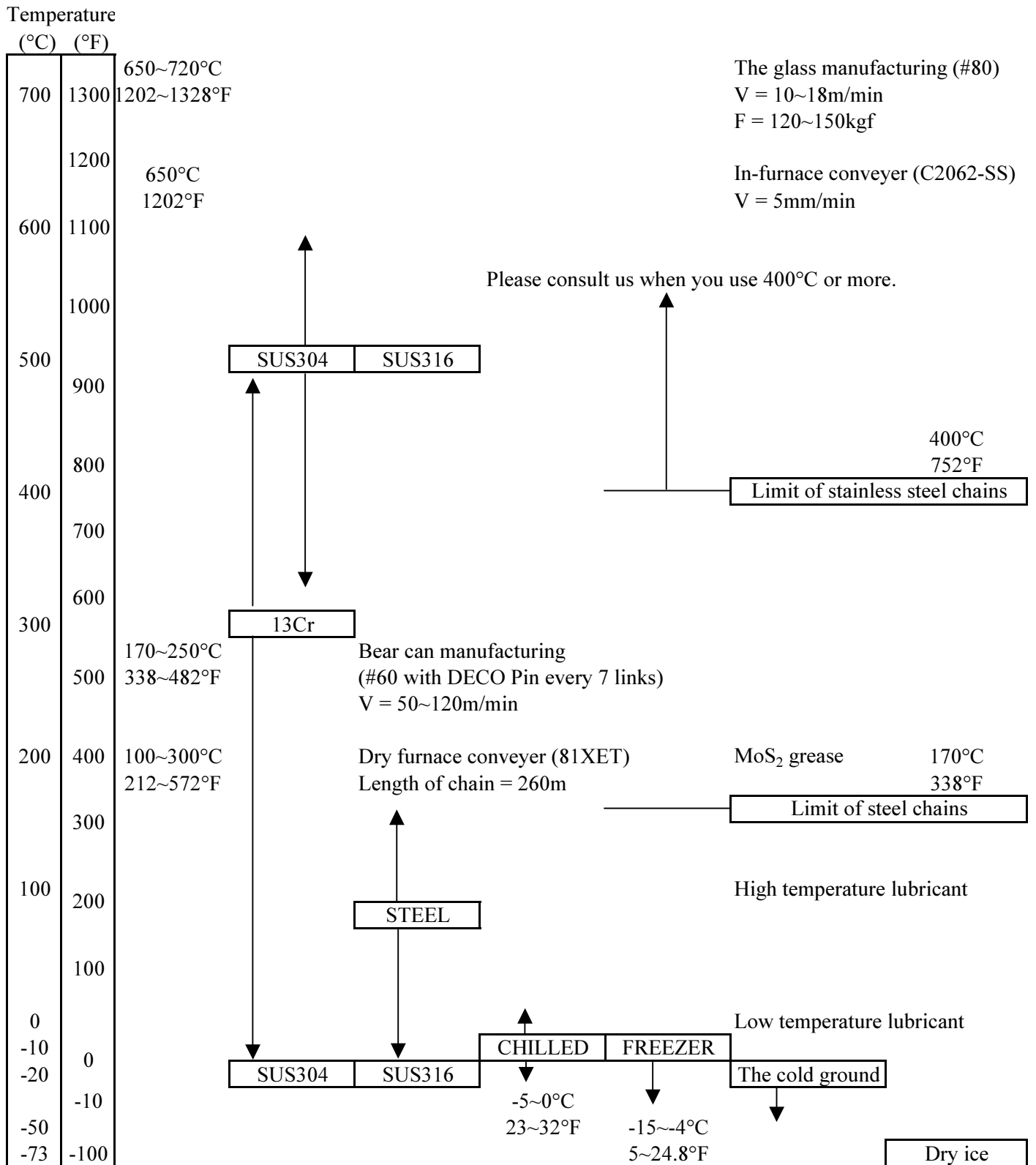

Fig.2 : Wear Resistance Test



Temperature Limit for Chain's use



Lubrication

Proper lubrication of roller chains is a very important factor in getting their best possible performance and longer lifetime.

No matter how well a transmission system is designed, if it is not properly lubricated, its service life will be shortened.

Abrasion between the pin and bushing causes roller chains to stretch. Therefore, these parts should be well lubricated.



The gap between the pin-link plate and roller-link plate on the slack side of the chain should be filled with lubricant.

The oil forms a film which minimizes wear of the pin and bushing thus increasing the chain service life.

It also reduces noises and cools down the chain running at high speed.

POINTS OF LUBRICATION

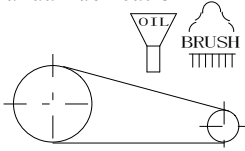
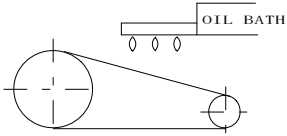
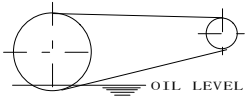
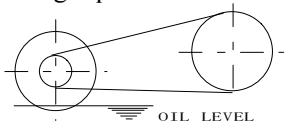
- 1) Fill and change oil periodically.
- 2) Generally, heavy oil and grease are not suitable as a lubricant.
- 3) Avoid mix of oil with another kind or other maker's.
- 4) Adequate lubrication quantity is also essential for a chain's longer service life.

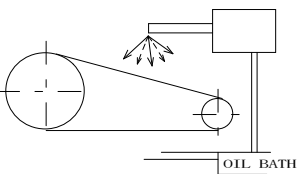
Type	Method	Amount
A	Manual lubrication 	<ul style="list-style-type: none"> ● Periodically to keep chain joints from drying.
	Dripping lubrication 	<ul style="list-style-type: none"> ● Usually 4~20 drops of oil per minute. ● Excess oil should be reserved in a simple case.
B	Oil bath lubrication 	<ul style="list-style-type: none"> ● Effective at medium and low speeds. ● To be dipped 6~12mm.
	Lubrication by slinger disc For large speed ratio 	<ul style="list-style-type: none"> ● Effective at rather high speeds. ● To be dipped 12~25mm at about 200m/min. circumferential speed of slinger disc.
	Lubrication by slinger disc For small speed ratio 	<ul style="list-style-type: none"> ● Case should be cleaned to remove impurities.
C	Forced lubrication 	<ul style="list-style-type: none"> ● Effective for heavy load, high power and high speed. ● Ab 4ltr/min. should be filled without oil shortage or heating up. ● Closed circulating lubrication system needs a clean tank or case.

SY Chain No.	Temperature [°C]							
	-10	0	40	50	-10	0	40	50
	?	?	?	?	?	?	?	?
	0	40	50	60	0	40	50	60
Lubrication Type	Type A•B				Type C			
~ SY 50	SAE 10	SAE 20	SAE 30	SAE 40	SAE 10	SAE 20	SAE 30	SAE 40
SY 60 ~ SY 80	20	30	40	50	10	20	30	40
SY100	20	30	40	50	20	30	40	50
SY120 ~	30	40	50	60	20	30	40	50

Comparison on Transmission Parts

[ROLLER CHAIN]

- Roller Chain, like a timing belt, is used to transmit power. Roller Chain is suitable for power transmission in slow and medium speed applications.
- There are 13 typical chain sizes from #25 to #240 (#25, #35, #40, #50, #60, #80, #100, #120, #140, #160, #180, #200 and #240).
- Compared to timing belts, roller chain drives have fewer tooth skipping problems.
- Forward/Backward transmission is available with roller chain along multiple shafts. Roller chain can be used for horizontal, vertical and inclined applications.
- Lubrication is required. Roller chain drives do give off some noise. Drive center distance is flexible.
- Maximum chain speed should be less than 7 m/sec. For general applications, 2~3 m/sec is suitable. For speeds lower than 0.83m/sec (50m/min), a slow speed selection method should be used.
- Roller chain wrap on the small sprocket should be more than 120 degrees. Normally its output is lower than 100kw.
- The normal speed ratio of roller chain can range up to 5:1. High transmission efficiency of 95~98% is expected.
- The minimum number of sprocket teeth is 13~16. For slow speed applications, sprockets with 9~10 teeth can be used.
- For sprockets smaller than 17 teeth, an odd number of teeth is recommended.
- Optimum distance is 30~50 times the pitch of the chain used. When there is a pulsating load, the distance should be up to about 20 times.
- Normal application temperature is -10°C~170°C.

[V BELT]

- V belts are used for high speed and medium speed transmission.
- Lubrication is not necessary. For this reason, equipment may be smaller.
- They have smaller vibration, shock, and driving noise compared to roller chain drives.
- When oil sticks to the V belt, transmission efficiency is greatly reduced.
- Drive center distance is flexible.
- V belt wrap on the small pulley should be more than 120 degree.
- There is slippage between the V belt and pulley. The slippage is about 1~3%.
- Maximum V belt speed should be less than 25m/sec.
- For general application, 5~18m/sec is suitable.
- Transmission efficiency is 80~95%. Standard speed ratio of V belt is up to 8:1.
- Standard output is less than 75kw. There are 6 types of V belt, of M, A, B, C, D & E.

[TIMING BELT]

- Timing belts have teeth to engage the pulley. Non-slip transmission is available.
- They are used as timing belts in automobile-type engines. It is also commonly used for transmission in office equipment.
- There are 6 sizes of timing belts with pitch ranging from 2.032, 5.08, 9.525, 12.70, 22.225 to 31.75.
- Transmission efficiency is 90~98%.
- Application temperature is -40°C~90°C.
- Pulley alignment is required.

Allowable Load of Roller and Attachments

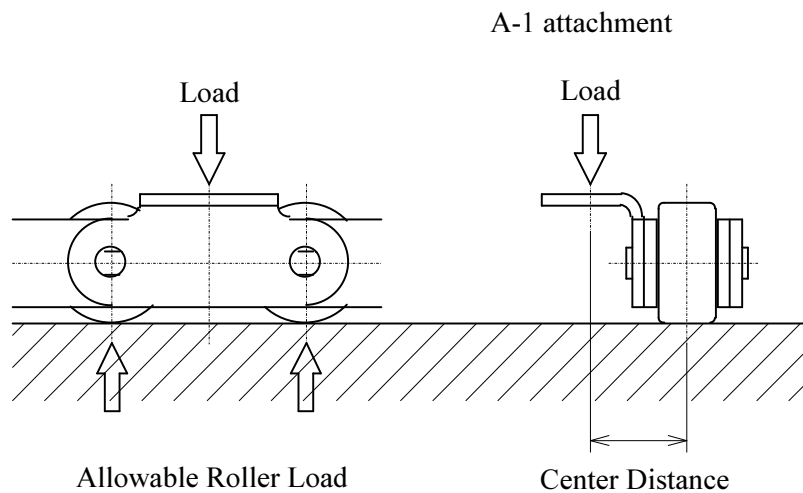

Table : 1 Allowable loads per one roller

Chain No.		Load (N)
C2040	40	147
C2042		637
C2050	50	196
C2052		931
C2060H	60	343
C2062H		1470
C2080H	80	540
C2082H		2400
C2100H	100	785
C2102H		2940

When the load is carried on the roller, the total weight of the chain and load per roller should not exceed the allowable roller load shown in Table 1.

Table : 2 Allowable attachment loads

Chain No.		Load (N)
	08B	150
	40	150
C2040		300
	10B	200
	50	280
C2050		520
	12B	290
	60	445
C2060H		1250
	16B	750
	80	685
C2080H		1850
	20B	900
	100	1050
C2100H		2760

BCL Connecting Links

The BCL (Bushed Center Link) connecting link employs special centerplates, each consisting of two with press fit on pitch hole bushing.

The bushing are carburized to resist wear.

The plate shape of BCL is Roller Link Plate.

When BCL is used, Offset Link cannot be used .

They are as easily installed and removed as slip fit centerplate connecting links.

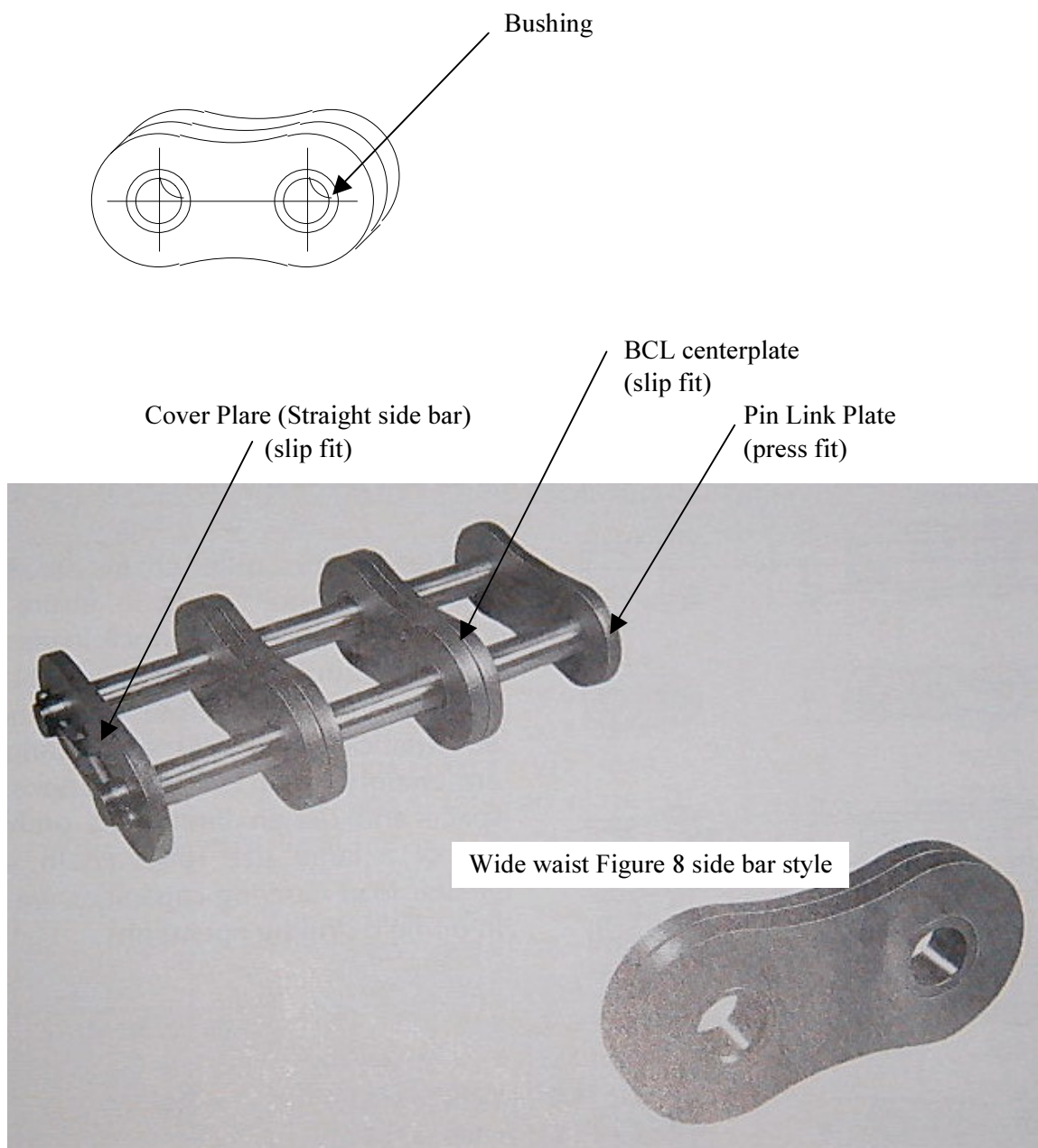

Feature of each Series

Chain No.	Rustless Chains				Meintenance Free Chains			Heavy Series Chains			
	AQUA	NP	SS	SSS	SL	SLR	MF	H	Oil-field	SUPER	S-S
35	○	○	○								
40	○	○	○	○	○	○					
50	○	○	○	○	○	○					
60	○	○	○	○	○	○		○			
80	○	○	○	○	○	○	○	○	○	○	
100	○	○	○		○	○	○	○	○	○	
120	○	○	○		○	○	○	○	○	○	
140	○	○	○		○		○	○	○	○	
160	○	○	○		○		○	○	○	○	251S
180	○							○	○	○	
200	○							○	○	○	264S
240	○							○	○	○	
06B		○	○	○							
08B	○	○	○	○		○					
10B	○	○	○	○		○					
12B	○	○	○	○		○					
16B	○	○	○			○	○				
20B	○	○	○			○	○				
24B	○					○	○	○			
28B	○					○	○				
32B	○					○		○			
C2040	○	○	○		○	○					
C2050	○	○	○		○	○					
C2060	○	○	○		○	○					
C2080	○	○	○		○	○					
C2100	○	○	○								
C2120	○		○								
C2160	○		○								
use temperature	-10~ 70°C		-40~ 400°C		-10~ 70°C		-10~ 170°C	-10~ 70°C			
Chain speed *1 (m/min)	#35 110	#40 84	#50 76	#60 67	#80 51	#100 43	#120 38	#140 32	#160 30	#180 29	#200 25
Allowable load *2	100%	90%	10%	15%	70%	80%	100%	108%	108%	135%	-

*1 type-A Manual or Drip Lubrication
*2 Standard roller chain is the base.

SBR[®]

BS STANDARD ROLLER CHAINS
ANSI STANDARD ROLLER CHAINS
STREIGHT SIDEBAR CHAINS
HEAVY SERIES ROLLER CHAINS
DOUBLE PITCH ROLLER CHAINS
HOLLOW PIN CHAINS
STAINLESS STEEL ROLLER CHAINS
SINTERD BUSHING CHAINS
MAINTENANCE FREE ROLLER CHAINS
LEAF CHAINS

Stainless Steel Chain

Chain No.	50% higher Allowable Load		
	High Power SSS Chain	Conventional	
		SS Chain	600 Series
35	41	27	41
	90	60	90
40	68	45	68
	150	100	150
50	105	70	105
	233	155	233
60	158	105	158
	348	232	348
80	270	180	270
	596	397	596
100	398	265	398
	878	585	878

How to Order Stainless Roller Chain

[Standard SS]	[High Power SSS]
#40-304SS	#40-304SSS
#40-316SS	#40-316SSS
	#40-600SSS

Series	Standard SS		High Power SSS			
SUS 304 Series	Price ratio vs.100	Bearing Pressure	(100 kg/cm ²) 1422 lbs/in ²	Price ratio vs.100	Bearing Pressure	(150 kg/cm ²) 2133 lbs/in ²
		Non-Magnetic Corrosion resistance Heat resistance All components made of SUS 304			Special treated pin (Hv 400 and up) All components made of SUS 304 Economy Price	

Series	Standard SS		High Power SSS			
SUS 316 Series	Price ratio vs.150	Bearing Pressure	1422 lbs/in ²	Price ratio vs.170	Bearing Pressure	2133 lbs/in ²
		Non-Magnetic Corrosion resistance Heat resistance Stress Corrosion Cracking resistance All components made of SUS 316			Special treated pin & roller (Hv 1000 and up) Wear resistance All components made of SUS 316	

Series	High Power SSS		
600 Series	Price ratio vs.250	Bearing Pressure	2133 lbs/in ²
		Pin made of heat treatment Special treated roller Wear resistance Other components made of SUS 304	

SY 304SS chain with all the components made of austenitic steel (SUS 304, 18-8 stainless steel)

The features of Stainless steel chain	Standard SS		High Power SSS		
	304 SS	316M SS	304 SSS	316M SSS	600 SSS
Shape of roller	Solid	Solid	Solid	Solid	Solid
Magnetic	○	◎	○	○	△
Corrosion resistance	○	◎	○	◎	△
Temperature resistance	○	◎	○	◎	○
Wear resistance	△	△	○	◎	◎
Stress Corrosion Cracking resistance	×	◎	×	×	×

◎ Excellent ○ Good △ Fair × Not Recommended

Matching and Tagging

Fig.1 Length measurement

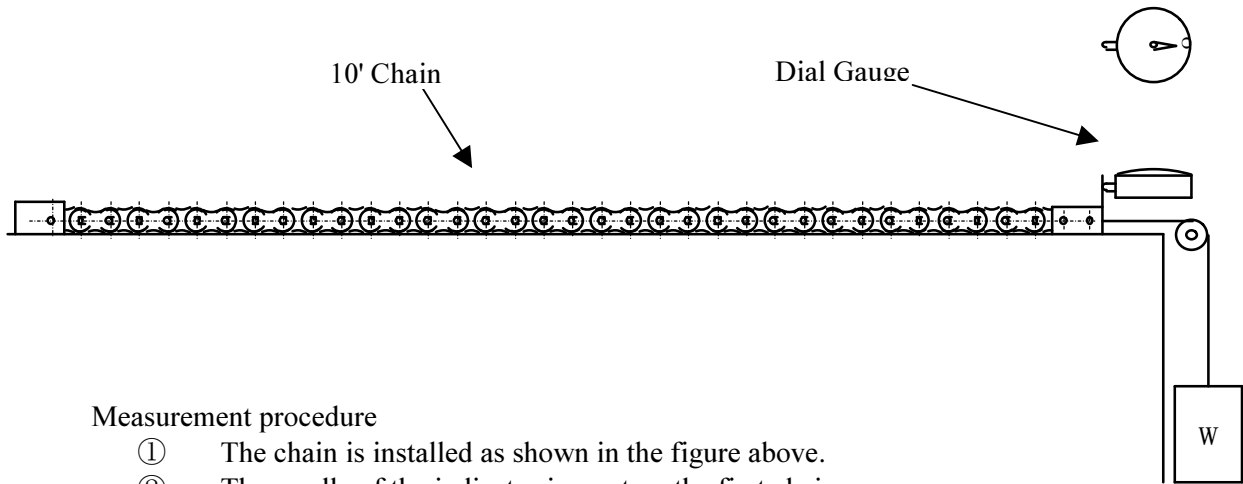

Measurement procedure

- ① The chain is installed as shown in the figure above.
- ② The needle of the indicator is reset on the first chain.
- ③ All the chain are measured.
- ④ The length is recorded and chains are sorted and tagged accordingly.
- ⑤ Install tagged chains in the following order. (R-1, R-2, R-3, …… L-1, L-2, L-3, ……)

Fig.2 Tagging

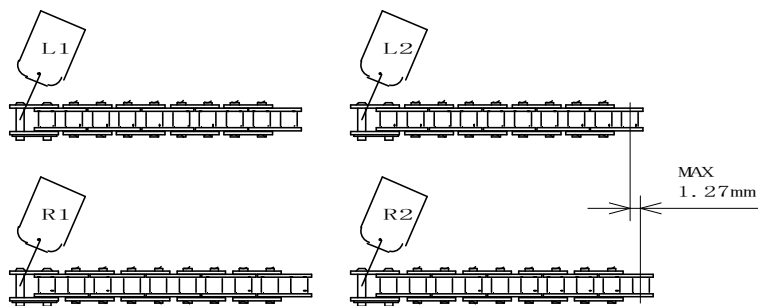

Extension tolerance of crosswise chain

- ① All the chains (10ft. length each) are measured.
- ② Tag is installed on each chain.
- ③ The tolerance between the two strands must be within 1.27mm.

Elastic Elongation

The Elastic Elongation graph shows how much elastic elongation the roller chain will undergo when it is subjected to tension.

The same graph as standard chain can be used for Heavy & Super series.

Results may vary slightly under different conditions.

The elastic limit of Roller Chain is 50% of its tensile strength and that of Stainless Steel Roller Chain is 30% of its tensile strength.

If you subject chains to tension greater than their elastic limit, they may no longer function properly and may cause damage or injury.

Never subject chains to tension greater than their elastic limit.

Fig.1 : #35~#140

Fig.2 : #160~#240

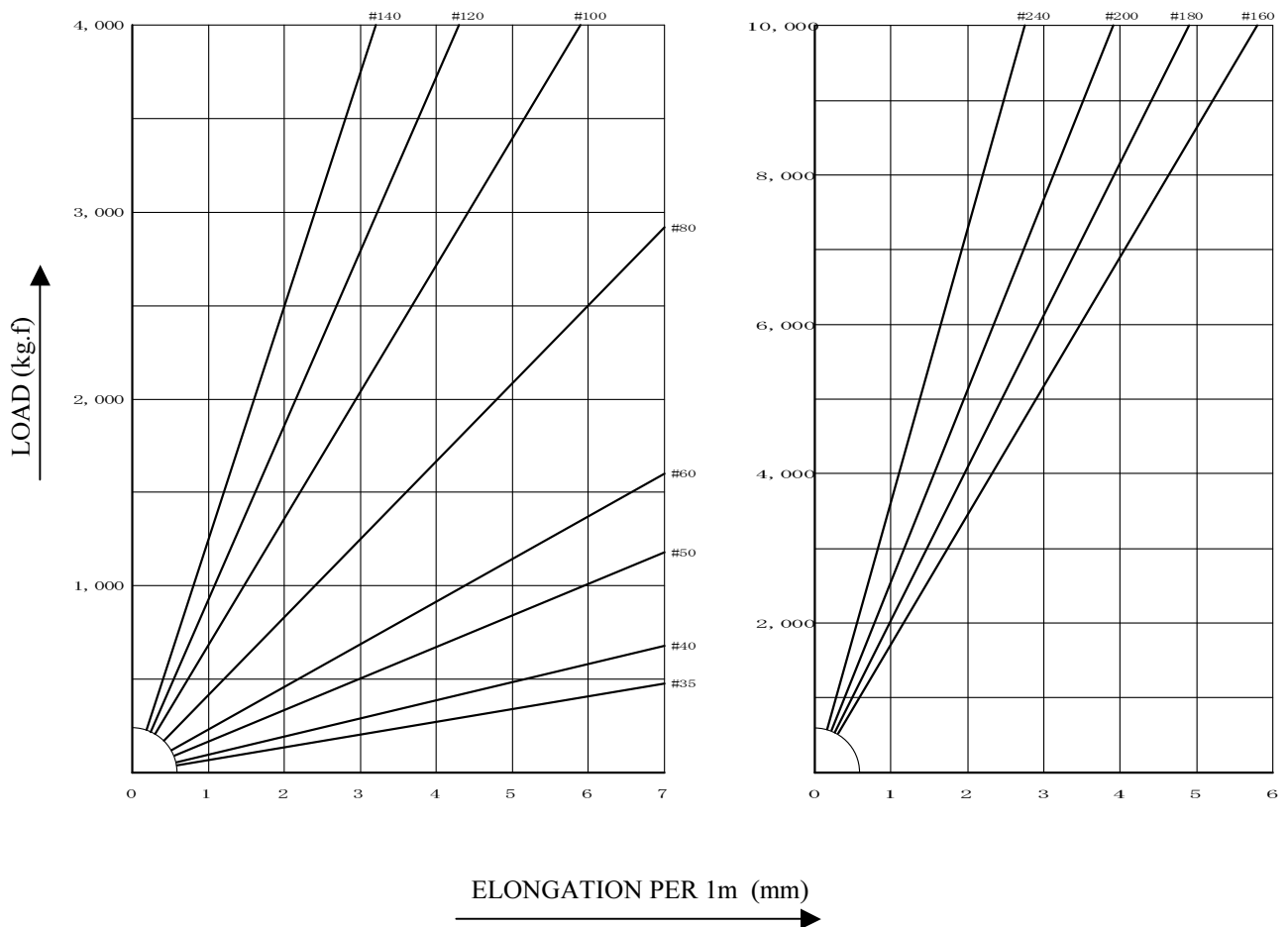

Number of chain pitches (=L)
Center distance in pitch (=C)

L = Number of chain pitches
C = Center distance in pitch
N₁ = Number of teeth (small sprocket)
N₂ = Number of teeth (large sprocket)

$$L = \frac{N_1 + N_2}{2} + 2 \cdot C + \frac{(N_2 - N_1)^2}{40 \cdot C} \quad \text{① expression}$$

$$C = \frac{1}{8} \left\{ 2L - N_2 - N_1 + \sqrt{(2L - N_2 - N_1)^2 - 0.811(N_2 - N_1)^2} \right\} \quad \text{② expression}$$

	Example-1	Example-2
Chain No.	#35	#35
Chain pitch (P)	9.525	9.525
(L)	42	42
mm	400.05	400.05
(N ₁)	10	11
(N ₂)	21	20

<Answer by ② expression>



(C)	13.133	13.172
mm	125.092	125.463

<Answer by ① expression>

mm	125.1	125.1
(C)	13.134	13.134
(L)	42.0	41.9

Trouble Shooting Hints

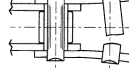
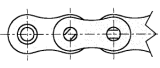
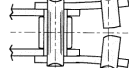
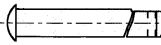
The below chart shows the most common chain failures and causes, but not necessarily the only ones.

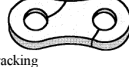
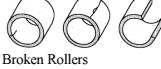
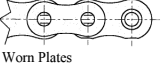
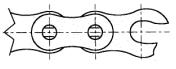
Problem	Possible Causes of Problem	Suggested Remedy	Problem	Possible Causes of Problem	Suggested Remedy
 Pin or Bushing Galling	<ul style="list-style-type: none"> •Overload •Inadequate lubrication 	<ul style="list-style-type: none"> •Properly lubrication •Replace chain when elongation 	 Broken Pins	<ul style="list-style-type: none"> •Extreme overload 	<ul style="list-style-type: none"> •Inspect the drive to determine the cause of high load •Redesign drive using a higher capacity chain
 Turned Pins	<ul style="list-style-type: none"> •Overload •Inadequate lubrication 	<ul style="list-style-type: none"> •Replace chains as soon as possible 	 Broken Pins (center)	<ul style="list-style-type: none"> •Loading is greater than pins dynamic capacity 	<ul style="list-style-type: none"> •Inspect the drive to determine the cause of high load •Redesign drive using a higher capacity chain
Excessive Noise	<ul style="list-style-type: none"> •Too little or too much slack •Chain obstruction •Loose chain guard or bearing 	<ul style="list-style-type: none"> •Adjust centers or take-up •Inspect & remove obstruction •Tighten bolts and check bearings 	 Broken Offset Link Pins	<ul style="list-style-type: none"> •Overload 	<ul style="list-style-type: none"> •One-pitch offsetlinks are not recommended •Redesign drive using a higher capacity chain
Chain Vibration	<ul style="list-style-type: none"> •Excessive chain slack •Center distance too long •stiff links 	<ul style="list-style-type: none"> •Adjust chain tensioned •Install idler •Lubricate or replace chain 	 Fatigue Failure	<ul style="list-style-type: none"> •Loading is greater than chain's dynamic capacity 	<ul style="list-style-type: none"> •Inspect the drive to determine the cause of high load •Redesign drive using a higher capacity chain
Wear on inside of link plate and one side of sprocket teeth	<ul style="list-style-type: none"> •Misalignment 	<ul style="list-style-type: none"> •Realign sprockets and shafts •Replace chain and sprockets if necessary 	 Cracking	<ul style="list-style-type: none"> •Stress corrosion cracking •Hydrogen embrittlement 	<ul style="list-style-type: none"> •Protect the chain from corrosion •Do not plating •Do not acid cleaning •Install anti-corrosive chains
Chain stiffens	<ul style="list-style-type: none"> •Excessive load •Misalignment •Inadequate lubrication •Corrosion 	<ul style="list-style-type: none"> •Replace chains with one of suitable strength •Inspect alignment •Clean and establish correct lubrication •Replace with corrosion resistant chain 	 Broken Rollers	<ul style="list-style-type: none"> •Foreign material between chain and sprocket tooth •Fatigue failure 	<ul style="list-style-type: none"> •Redesign chain speed and load •Shield drive from foreign matter
Chain Climbs Sprockets	<ul style="list-style-type: none"> •Excessive chain wear •Excessive chain slack •Inadequate lubrication •Sprocket tooth wear 	<ul style="list-style-type: none"> •Replace chain •Install tensioned if necessary •Replace sprocket 	 Worn Plates	<ul style="list-style-type: none"> •Bottom of plates worn due to rubbing on guides 	<ul style="list-style-type: none"> •Chain should be replaced when wear becomes over 5% of the plates height
 Fractured Plate	<ul style="list-style-type: none"> •Extreme overload 	<ul style="list-style-type: none"> •Inspect the drive to determine the cause of high load •Redesign drive using a higher capacity chain 			

Sprockets for Double Pitch Chain

Fig.1

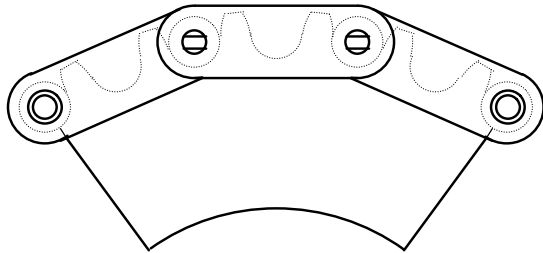

Small Roller Type

Fig.2

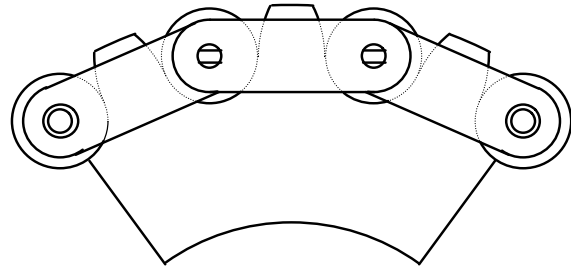

Large Roller Type

All double pitch chain with large rollers require sprockets designed specifically for their use.

Small roller double pitch chain requires specifically designed sprockets only if using a sprocket with fewer than 30 teeth.

Small roller type double pitch chain engages every other sprocket tooth.

Small roller double pitch chain may use single pitch sprockets of 30 teeth or more.

A sprocket with an odd number of teeth, however, is recommended for small roller type double pitch chain when a sprocket of more than 30 teeth is used.

When using a sprocket with an odd number, each tooth is engaged every other revolution. This doubles the sprocket life.

Example of Chain's Indication

No.	Example of number	Sketch
1	40-1LA1	
2	40-2LA1	
3	40-2LA1RL	
4	40-3LA1	*
5	40-1L2LA1	
6	40-1L3LA1	*
7	40-2L4LA1	*
8	40-2L2L4LA1	*
9	40-2L3L5LA1	*
10	40-2L alternating A1	
11	40-4L alternating A1	*
12	40-2LD-1	
13	40-4LD-3	*

No.	Example of number	Sketch
1	100	C/L
2	99+C/L	C/L
3	99+O/L	O/L
4	98+O/L	O/L
5	97+C/L•O/L	C/L•O/L
6	97+O/L•C/L	O/L•C/L
7	97+C/L•C/L	C/L•C/L
8	99 PL-PL	PL-PL
9	99 RL-RL	RL-RL
10	100 PL-RL	PL-RL
11	100 endless	Riveted endless
12	100 C/L endless	C/L endless
13	99 O/L endless	O/L endless
14	99 C/L•O/L endless	C/L•O/L endless

Notes) When both ends are outer links, Both riveted end pins are taken out from both end outer links.

Notes) 1.*Mark : When the space between attachments is an odd number, Link with attachment starts from the 2nd link (Inner link) from the beginning.
When the space between attachments is an even number, Link with attachment starts from the 3rd link (Outer link) from the beginning.
2. When this space between attachments is not equal, please let us know the space of attachments with your sketch.

The Features of **SBR** Chain

Solid Bushing and Roller

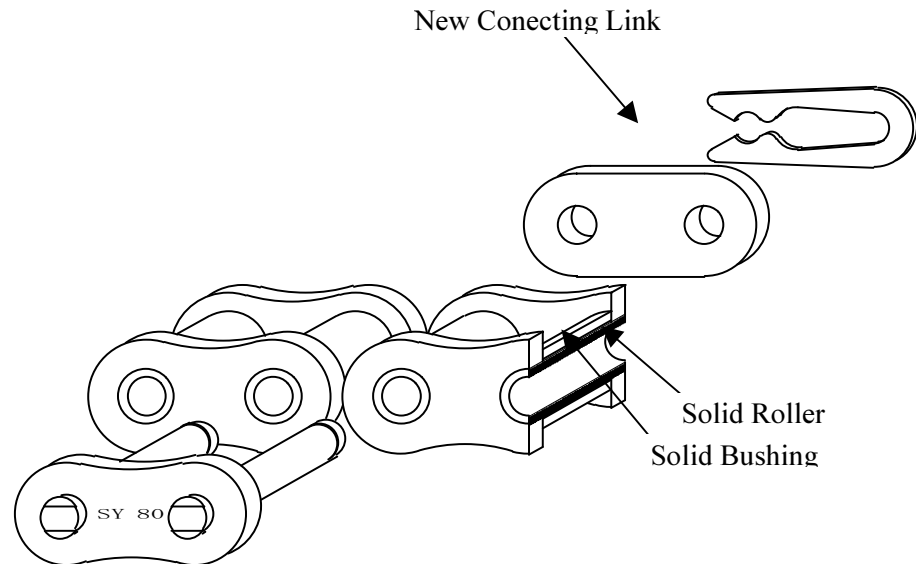

The Development and Features of **SBR** Chain

SBR Chain (started selling in July 1987) SOLID BUSHING & SOLID ROLLER

The chains consist of seamless components such as solid bushings and rollers.

The chain life is longer than that of curled bushing and rollers due to the higher resistance to elongation.
Sugiyama is the only company in the world that supplies all of its standard chains with solid bushings and solid rollers.

Neo SBR Chain (started selling in July 1997, patent pending)

With special coating on its pins and bushings,

Neo SBR chain has greater rust resistance and higher wear resistance for longer chain life.

The improved full-strength connecting link allows for full maximum loads by equally the fatigue strength of the chain itself.

Silver SBR Chain (started selling in July 2002, patent pending)

The chain is made with a special surface treatment.

Both our ANSI type simplex & duplex silver SBR chains have about a 25% higher fatigue strength than our previous standard chains and other manufacturers standard chains.

Pin's of Fatigue Breakage Caused by Pitting Corrosion

Drawing-1

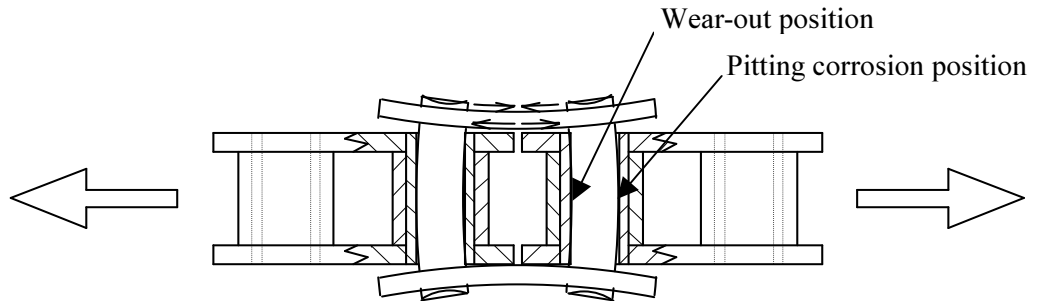

Drawing-2

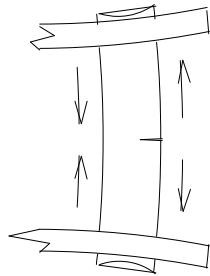

Please refer to both drawing 1 & 2.

Picture-1 Pitting corrosion of dangerous area



Picture-2 Fatigue breakage

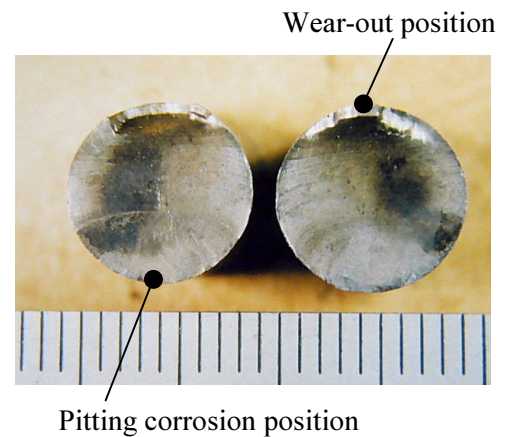

When pitting corrosion of pin is caused pin's fatigue breakage by sea wind while chains are used outside, As indicated on Drawing 2, the center of pin becomes the starting point of the fatigue breakage.

Regarding the application such as Straddle Container Carrier in port and Lumber Conveyer Machine, when chains are used under atmosphere which dangerous area of pin may get corroded, we recommend you specially coating pin for anti-pitting corrosion.

Roller Chain Number

【BS type】

Company Name (Brand)	SUGIYAMA (SY)	TSUBAKI (RS)	DAIDO (DID)	ENUMA (EK)	KAGA (KCM)	ORIENTAL (OCM)
STD	06B	RF 06B	DID 06B	EK 06B	KCM 06B	OCM 06B
	08B	RS 08B	08B	08B	08B	08B
Straight Sidebar	08B-F	RF 08B				
Nickel-plated	08B-NP	08B NP				
Sinterd Steel	08B-SLR					
Heavy duty	24B & 32B					
	264S					

【ANSI type】

Company Name	SUGIYAMA	TSUBAKI	DAIDO	ENUMA	KAGA	ORIENTAL
STD	SY 40	RS 40	DID 40	EK 40	KCM 40	OCM 40
Straight Sidebar	40 F	RF 40	40 F	40 C	40 F	40 E
Environment Resistant	50 AP	50 WP	50 E		50 DC	50 DT
	AQUA-Proof	50 DP	50 WE		50 BA	Super shield
Nickel-plated	40 NP	40 NP	40 N	40 NP	40 N	40 N
Sintered (Bushed)	40 SL	Lambda	—		40 SL	40J-SEB
Sintered (Roller)	40 SLR	RSD 40-Λ	40 UR		40 NL	40J-SER
Heavy duty	100 HE	RS 100HT	DID 100HK		100 HE	100 H
SUPER	SUPER 100	SUPER 100	Hi-PWR-S100		100 LL	HS 100
SUPER H	SUPER 100H	SUPER 100H	Hi-PWR-S 100HK		100 HLL	—

【Stenless Steel Chain】

Company Name	SUGIYAMA	TSUBAKI	DAIDO	ENUMA	KAGA	ORIENTAL
SUS304	50 SS	50 SS	50 SS	50 SS300	50 SS	50 SUS
SUS316	50 SS316	50 NS				50 SAC
600	50 SS600	50 AS	50 SSK	50 SS600	50 AS	50 SPH

【Special Chain】

Company Name	SUGIYAMA	TSUBAKI	DAIDO	ENUMA	KAGA	ORIENTAL
Side Bow Chains	50 SB	50 SB	50 FX	50 SB	50 SB	50 C
Hollow Pin Chains	50 HP	50 HP	50 HP	50 HP	50 HP	50 HP
Solid Bushing Chain	—	—	100 D	—	—	100 LR
O-Ring Chain	—	—	100 LD	—	—	—
Low temperature	—	60 KT	60 TK	—	—	60 K

The kind of attachment

Technical Support

(20)

ATTACHMENT CHAINS

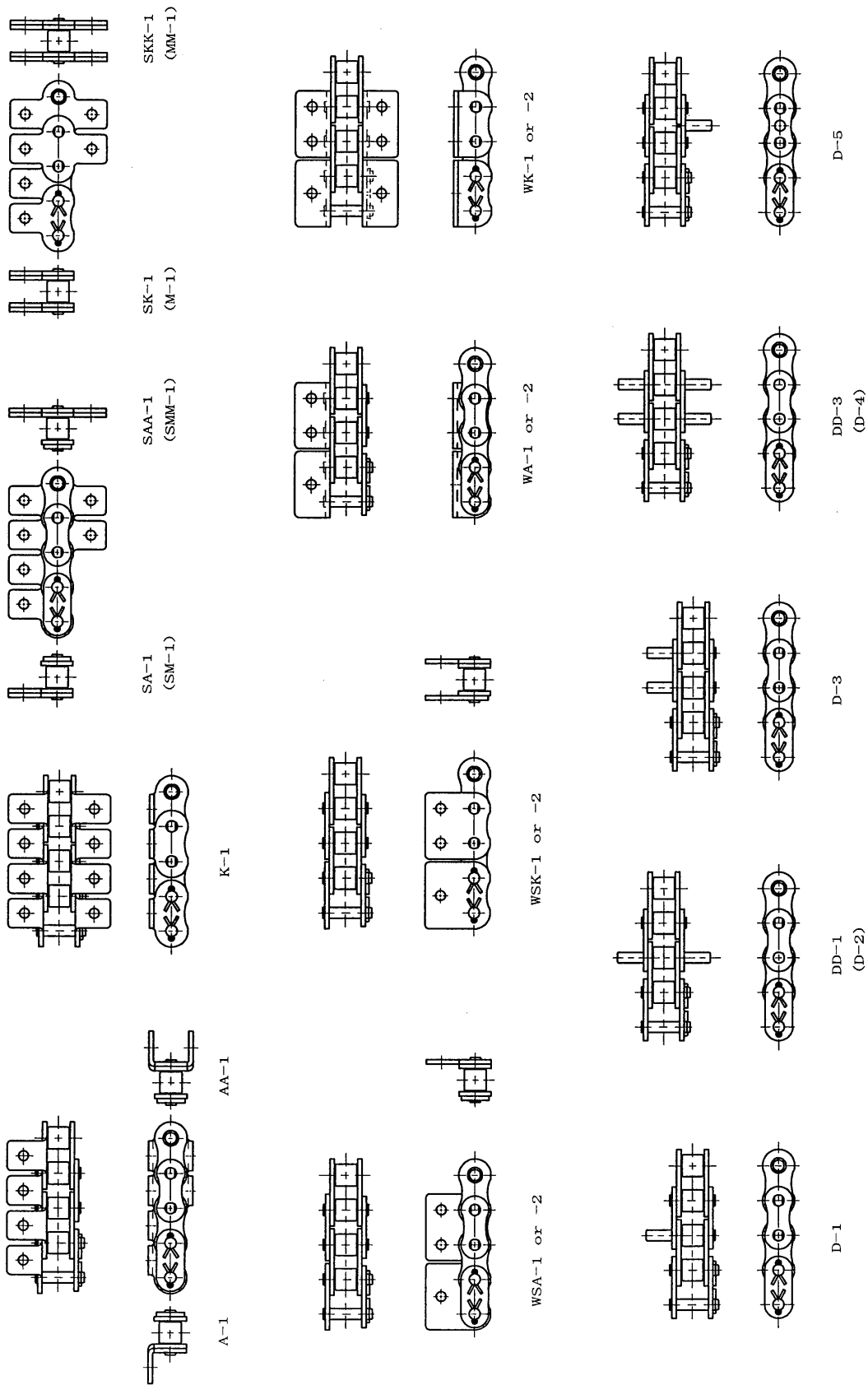

Sugiyama Chain co.,ltd.

Features and Drive Direction of Offset Type Bushed Chain

[Features]

1. Offset type bushed chain can be easily connected using only one link unit of the chain.
2. There is very little slippage between the bushing and the sprocket teeth.

[Superior Wear Resistance]

The correct drive direction of offset type bushed chain is critical.

Generally, the drive center distance of conveyor chain is long and the chain speed is slow.

As a result, each individual chain link contacts the sprocket less often, but each individual sprocket tooth has more cumulative wear because it comes in contact with the chain's entire length.

This results in more wear to the sprocket than to the chain itself.

Sprocket wear can be reduced by using the proper drive direction.

The recommended drive direction *****(when used as a conveyor chain)***** is indicated in figure 1.

As the chain is pushed, slippage occurs between the pin and bushing of the chain rather than between the sprocket and chain bushing. Sprocket wear is therefore reduced.

When installed as in Figure 2, there is slippage not only between the pin and the bushing, but also between the sprocket and the bushing as the chain pulled around the sprocket. This creates more sprocket wear.

In certain other cases, however, the chain drive feed direction should be reversed.

Figure 2 should be referenced in the following applications:

1. When offset chain is used as a power transmission chain rather than a conveyor chain.
2. When the chain runs at a speed high enough to blow away the conveyed product.
3. When used as a Drag chain (the flat side of the barrel is used as a scraper).

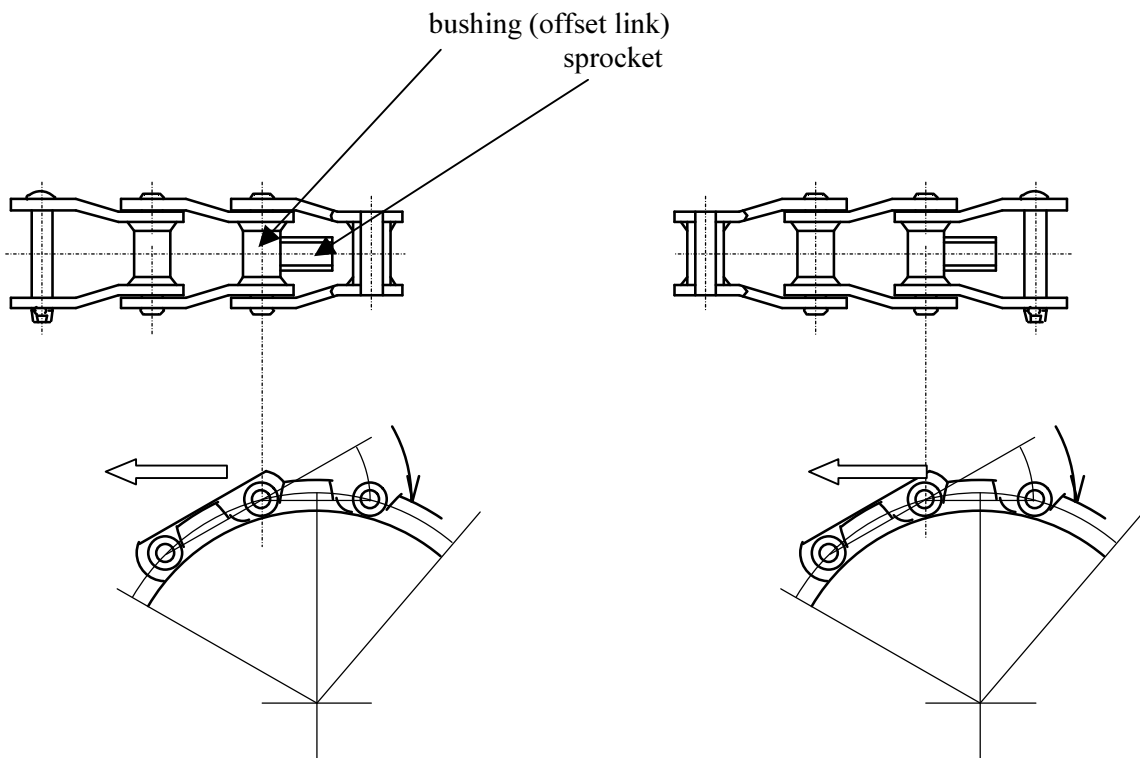

figure-1 ○

figure-2 ×

Safeguarding of Hazards

- Safe from accident by using the cover at the hazard place.

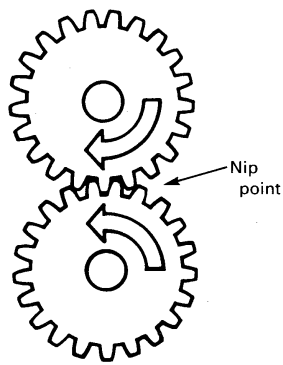

FIG. 1 ROTATING MOTION

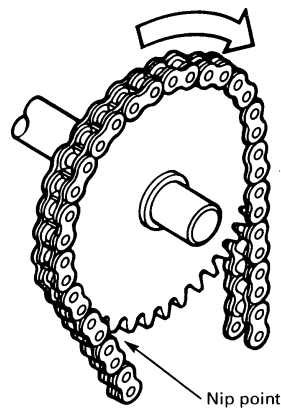

FIG. 2 ROTATING MOTION

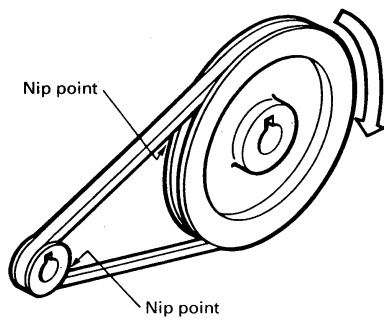

FIG. 3 ROTATING MOTION

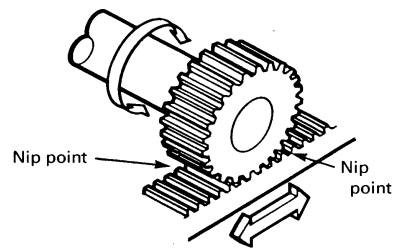

FIG. 4 ROTATING / RECIPROCATING MOTION

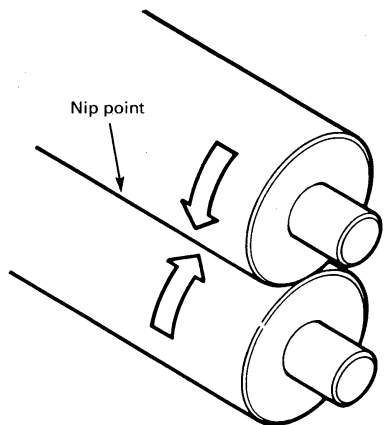

FIG. 5 ROTATING MOTION

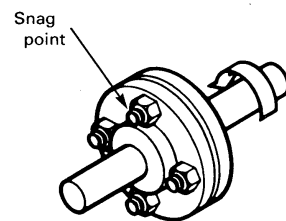

FIG. 6 ROTATING MOTION

From ASME B15.1-2000(Safety Standard for Power Transmission Apparatus)

Safeguarding of Hazards

- Safe from accident by using the cover at the hazard place.

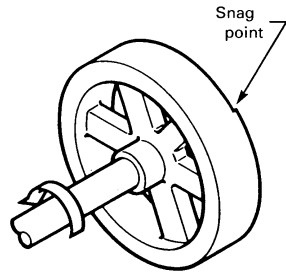

FIG. 7 ROTATING MOTION

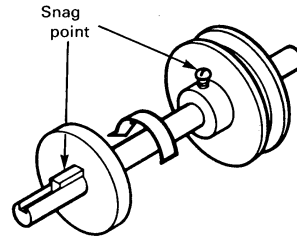

FIG. 8 ROTATING MOTION

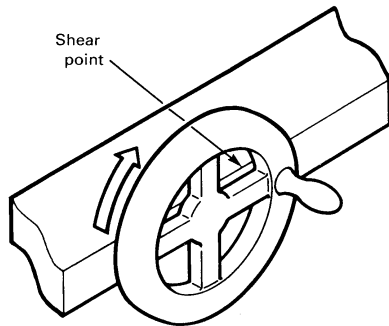

FIG. 9 ROTATING MOTION

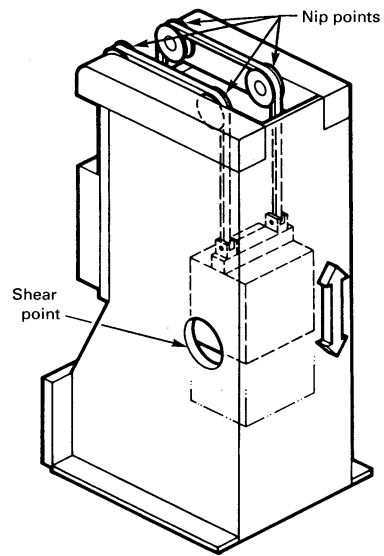

FIG. 10 ROTATING / RECIPROCATING MOTION

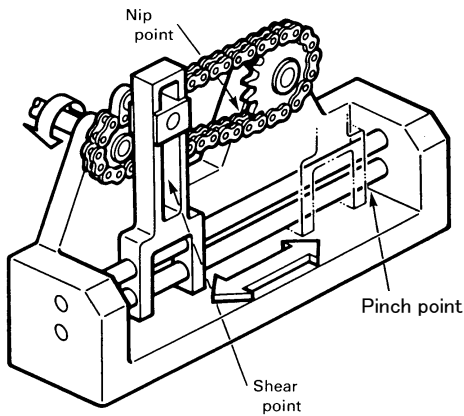

FIG. 11 ROTATING / RECIPROCATING

From ASME B15.1-2000(Safety Standard for Power Transmission Apparatus)

Wear life and measuring method of a chain

【Wear life of chain】

- ① If chain happen elongation while use it for long time under wear out, it should be replaced with new one
Recommendation of sprocket teeth number: minimum teeth number 9 to maximum teeth number 120.

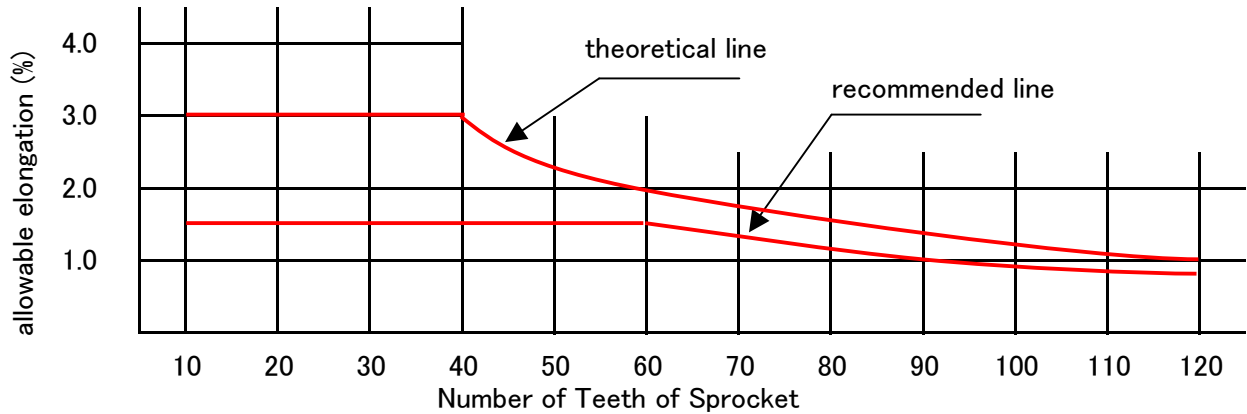

【Measuring method】

Chain must be measured with approxmatly one % of the minimum breaking strength applied.

- ② Elongation measuring (caliper)
As indicated bellow, about 6 to 10 links are measured.

$$\text{measured length} = \frac{L1 + L2}{2}$$

$$\text{standard length} = \text{chain pitch} \times \text{link number}$$

$$\text{elongation}(\%) = \frac{\text{measured length} - \text{standard length}}{\text{standard length}} \times 100$$

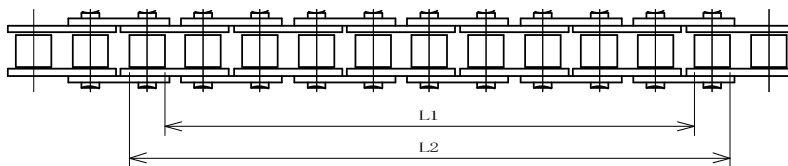

- ③ Elongation measuring (tape measure)

This can be done by removing the chain from the sprockets and hanging in a vertical position or placing on a flat horizontal surface and applying the measuring load needed for each individual size chain.

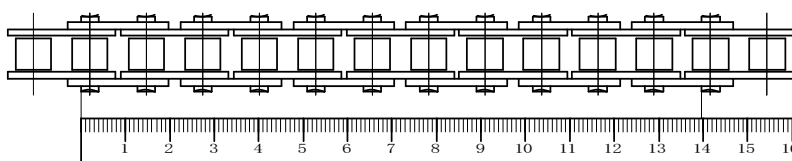

Chain Maximum Speed (V m/min)

In case of Maximum Speed	exception		
	(m/sec)	→	(m/min)
	7		420
	generally		
	2-3	→	120-180
In case of Low Speed	maximum		
	(m/sec)	→	(m/min)
	0.83		50

Lubrication shown below

$$V = \frac{0.3 N}{\sqrt{P}}$$

P = Chain Pitch
N = Number of Spocket teeth

Complete lubrication

$$V = \frac{2 N}{\sqrt{P}}$$

【for example】

Chain No. #140
P = 44.45
N = 22

Lubrication shown below

$$V = \frac{0.3 N}{\sqrt{P}} = \frac{0.3 \times 22}{\sqrt{44.45}} = 0.99 \text{ (m/sec)} \rightarrow 59 \text{ (m/min)}$$

Complete lubrication

$$V = \frac{2 N}{\sqrt{P}} = \frac{2 \times 22}{\sqrt{44.45}} = 6.6 \rightarrow 396$$

【Lubrication】

Suitable Chain Speed

Manual Lubrication → below 15 m/min

Drip Lubrication → from 15 to 30 m/min

Oil Bath lubrication → from 30 m/min and UP